

R. A. RYRIE.
WRENCH.

APPLICATION FILED APR. 27, 1908.

910,961.

Patented Jan. 26, 1909.

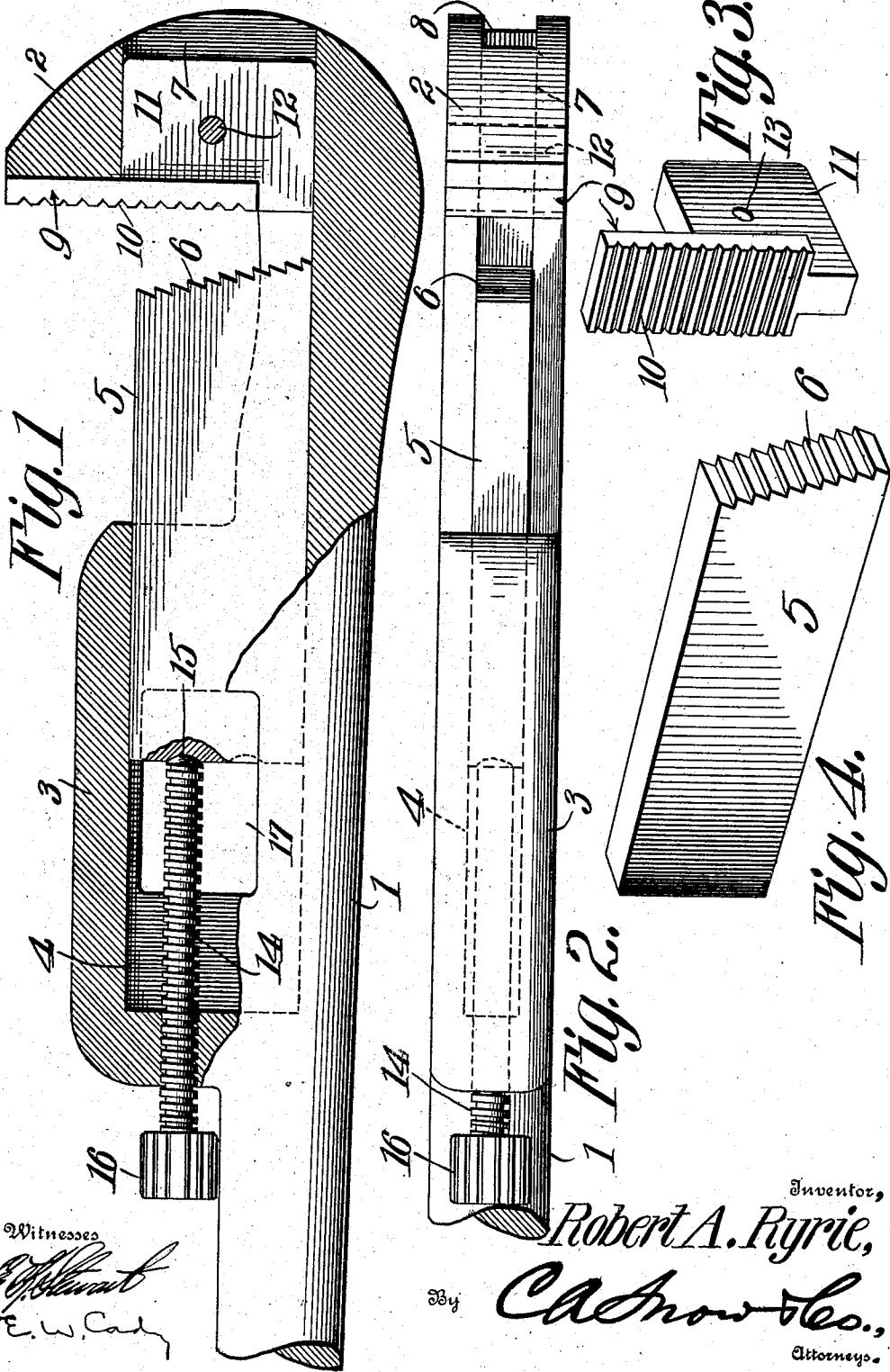

Witnesses
E. W. Carr

Inventor,
Robert A. Ryrie,
By *Cashow & Co.,*
Attorneys.

UNITED STATES PATENT OFFICE.

ROBERT A. RYRIE, OF CAMDEN, NEW JERSEY, ASSIGNOR OF ONE-HALF TO CHARLES A. RUDOLPH, OF CAMDEN, NEW JERSEY.

WRENCH.

No. 910,961.

Specification of Letters Patent.

Patented Jan. 26, 1909.

Application filed April 27, 1908. Serial No. 429,514.

To all whom it may concern:

Be it known that I, ROBERT A. RYRIE, a citizen of the United States, residing at Camden, in the county of Camden and State of New Jersey, have invented a new and useful Wrench, of which the following is a specification.

This invention relates to wrenches, and has especial reference to pipe wrenches in which serrated jaws are used to clamp a pipe or other object.

The invention has for its object to provide an improved wrench in which the jaws may be readily removed, and which will be light, simple in construction, durable, and economical to manufacture.

The invention consists of a wrench, and in details thereof, as hereinafter set forth, and claimed.

Referring to the drawings:—Figure 1 is a side view in elevation, and partly broken away, of a wrench constructed in accordance with this invention. Fig. 2 is a front edge view thereof, in elevation. Fig. 3 is a perspective view of the fixed jaw, detached. Fig. 4 is a perspective view of the movable jaw, detached.

1 indicates the bar or frame of the wrench provided with the head 2, and the main portion 3, spaced from the head 2, and in alinement therewith. The portion 3 is formed with a longitudinal recess 4, in which is mounted a slidable jaw 5, of any suitable shape, and as here shown consisting of an elongated rectangular bar, provided with the preferably serrated end 6. The head 2 is formed with a socket 7 in alinement with, and corresponding in shape to the recess 4, the socket 7 extending through the head 2.

Mounted in the head 2 is a fixed jaw 9, of any suitable shape, and as here shown consisting of a rectangular serrated plate 10, and a rectangular shank 11 seated in the socket 7, and held therein by suitable means, such as a pin or wedge 12, extending through a hole in the head 2, and through the hole 13, in the shank 11.

The movable jaw 5, may be operated by any suitable means and as here shown by means of a screw rod 14, extending through and in threaded connection with the lower end of the main portion 3, and projecting into

the recess 4. The inner end of the rod 14 is preferably not connected to the jaw 5 but rests against it in a centering recess 15, and the outer end of the rod 14 has a milled head 16 for turning the same. The inner end of the rod 14 may be detachably connected with the jaw 5, if desired. The length of the movable jaw 5, being greater than the distance of the space between the end of main portion 3 and the head 2 in order to remove the jaw 5, it must be slid through the socket 7 in the head 2 and out of the same.

The jaw 9 may be readily removed for sharpening or renewal by removing the pin 12, and the movable jaw 5, may be also readily removable for renewal or sharpening, the jaw 9 being removed, and the jaw 5, being pushed through the socket 7, and the opening 8 in the head 2, and out of the same. The rod 14 may be readily removed from the main portion 3, for renewal or repair.

In use the rod 14 only acts on the jaw 5 to advance it towards the jaw 9, the jaw 5 dropping back into recess 4, when the rod 14 is moved back in the recess 4, or the jaw 5 may be slid back by hand.

The sides of the main portion 3, are each provided with an opening 17, by means of which access may be had to the rod 14, and jaw 5 if desired, and which also adds to the lightness of the frame 1.

Having described the invention, I claim:—

1. In a wrench, a handle member having a main portion or guide provided with a longitudinally disposed recess, the end of the handle having a stationary head provided with an opening in alinement with said recess, a stationary jaw having a shank extending into and confined within said opening, and a movable jaw adjustably mounted in the recess and movable bodily from the recess and through the shank receiving opening when the stationary jaw is removed from position.

2. In a wrench, a handle provided with an enlarged central portion having a longitudinally disposed recess for the reception of the movable jaw, the handle having at one end an integral head provided with an opening in direct line with the recess and of a contour corresponding to that of the recess, a stationary jaw having a shank member fit-

ting within the opening, a locking pin extending through alining openings formed in the head and shank, and a movable jaw mounted in the recess said jaw being bodily
5 removable through the shank receiving opening for removal or repair.

In testimony that I claim the foregoing as

my own, I have hereto affixed my signature in the presence of two witnesses.

ROBERT A. RYRIE.

Witnesses:

GEO. W. AMME,
GEO. H. AYER.